

EBONOVA

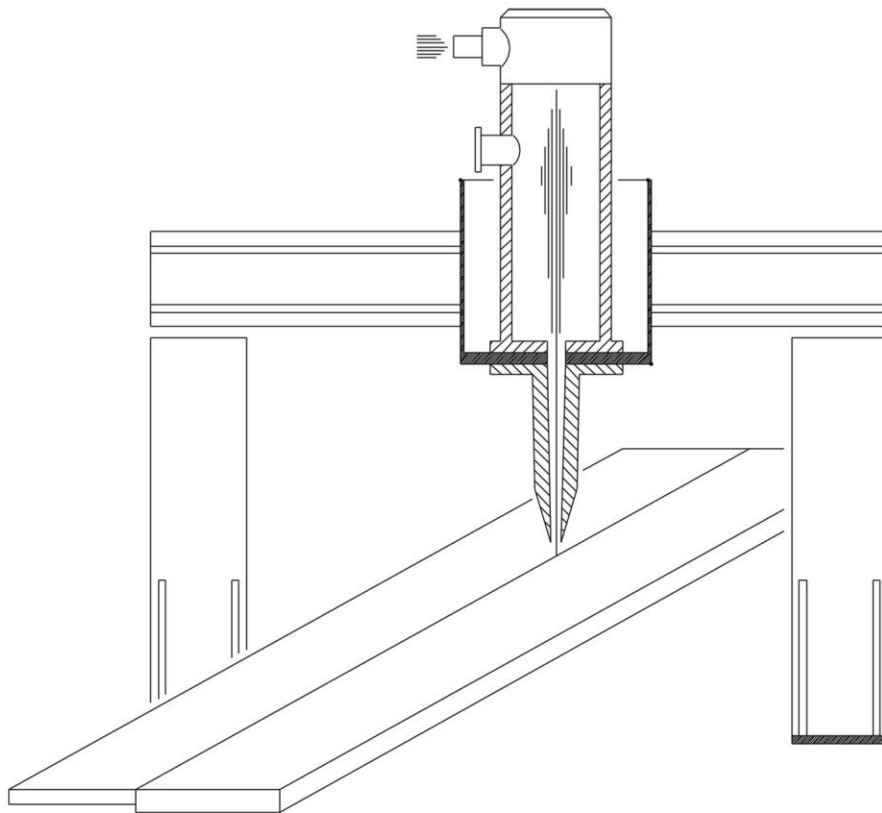

***Electron beam welding
at atmospheric pressure***



The electron beam at atmosphere A re-discovered welding process

History of electron beam welding

1948 to 1951 the physicist Dr. K. H. Steigerwald (ZEISS) pioneers its development and builds the first electron beam (EB) processing machine for drilling watch jewels. With the discovery of the deep penetration welding in the following fifties whole over the world welding, drilling, hardening and remelting with the high energy electron beam in vacuum and also at atmospheric pressure (Lorenz/HERAEUS) was investigated.

A first milestone with Electron Beam Welding (EBW) in vacuum was a depth-width-ratio of the seam of 10:1 and a welding depth up to 5 mm.

The EBW in vacuum was developed more and more. Today depth-width-ratios of 50:1 and welding depths up to 300 mm are possible. In contrast, the EBW at atmospheric pressure (Non Vacuum Electron Beam Welding, NVEBW) didn't found any application in Europe.

In many industrial branches, as for example the aeronautic and automotive industry, the EBW became an irreplaceable joining procedure. The American industry early recognized the power of the NVEBW and for economical reasons it was first used in the automotive industry because of the high production volumes.

At the beginning of the sixties the LASER was discovered and with big financial advancement all over the world developed for industrial application. Today, laser beam welding is one of the most important joining processes.

While EB sources with more than 60 kW beam power are commercial, the maximum laser beam power is in the range of 20 kW.

Due to a lot of activities at German universities and institutes the NVEBW was re-discovered and together with industrial partners developed further in the nineties

Re-discovery - new introduced

A 30 kW **Steigerwald Strahltechnik** electron beam generator is operating at the **ISF** in Aachen since many years. The orifice system (DSS) was also developed at this generator.

Steigerwald Strahltechnik introduced together with the **ISF** in Aachen the high speed EBW at atmospheric pressure (NVEBW) successfully from laboratory operation to industrial production.

Concepts for lightweight constructions presently led by the aeronautic and automotive industry, has forced designers to use light-weight alloys of aluminium, magnesium and titanium. The use of the Finite-Element Methods (FEM) permits the design of complex components and semi-finished products for example *Tailored Blanks*.

In order to achieve the high production volumes, demanded by the automotive industry, high welding speeds with constant quality and low operating costs are absolute requirements.

Here the electron beam welding at atmospheric pressure NVEBW with beam powers up to 30 kW provides new prospects as an alternative to CO₂-laser beam welding.

Accurate requirements such as high speed welding production rates, low energy input for minimal thermal distortion and savings in filler material have led to the introduction of non-vacuum EB; NVEBW.

The diverging and high-energy electron beam permits a good gap bridging without using filler material and is insensitive to working distance variations. Low heat input from the electron beam minimises thermal distortion of the workpiece.

The energy transformation from the electron beam to the work-piece is independent of the material and the surface condition. The total efficiency of a NVEBW machine is above 60 %. For all these reasons, the NVEBW is a very economical solution for mass production.

Fields of application for NVEBW machines

- Automotive Industry
 - Tailored Blanks
 - Instrument panel beams
 - Exhausts
- Equipment construction
- Welding laboratories
- Job shops

Established Electron beam technology

The difference

Principle of electron beam generating

The beam is produced and controlled by the EB generator within the triode system. The electrons emerge from the cathode consisting of a tungsten filament which has been heated to approx. 2,500 °C. The direct heating of the tungsten filament ensures trouble-free operation. Voltages of up to 150 kV between cathode and anode accelerate the electrons towards the workpiece. A bias cup is arranged between anode and cathode, which is used as control electrode. An electromagnetic lens focuses the diverging electron beam to a spot with high power density. Hitting the workpiece surface the kinetic energy of the electrons is mostly transformed into heat, a small part is emitted as X-rays. The generator column and the high voltage power supply result in a standard assembly. Further details of the **Steigerwald** electron beam generator you can find in our leaflet **EBOGEN**.

Established Electron beam technology

Steigerwald Strahltechnik uses the same EB high voltage generator type **EBOGEN** both, for electron beam welding and drilling in vacuum and for the NVEBW. The **EBOGEN** generator is established in industry since many decades. Consequently for the NVEBW only standardized components are used.

The difference

In contrast to the EBW in vacuum the working chamber is replaced by an orifice system. The evacuation time is eliminated, as the orifice system and the generator column are permanently kept under vacuum. The electron beam is guided to the atmosphere from high vacuum over fine vacuum and rough vacuum.

Whereas with the VEBW long working distances can be realized by changing lens current, the distance for the NVEBW is fixed. Differences in the working distance are equalized by moving the electron beam generator.

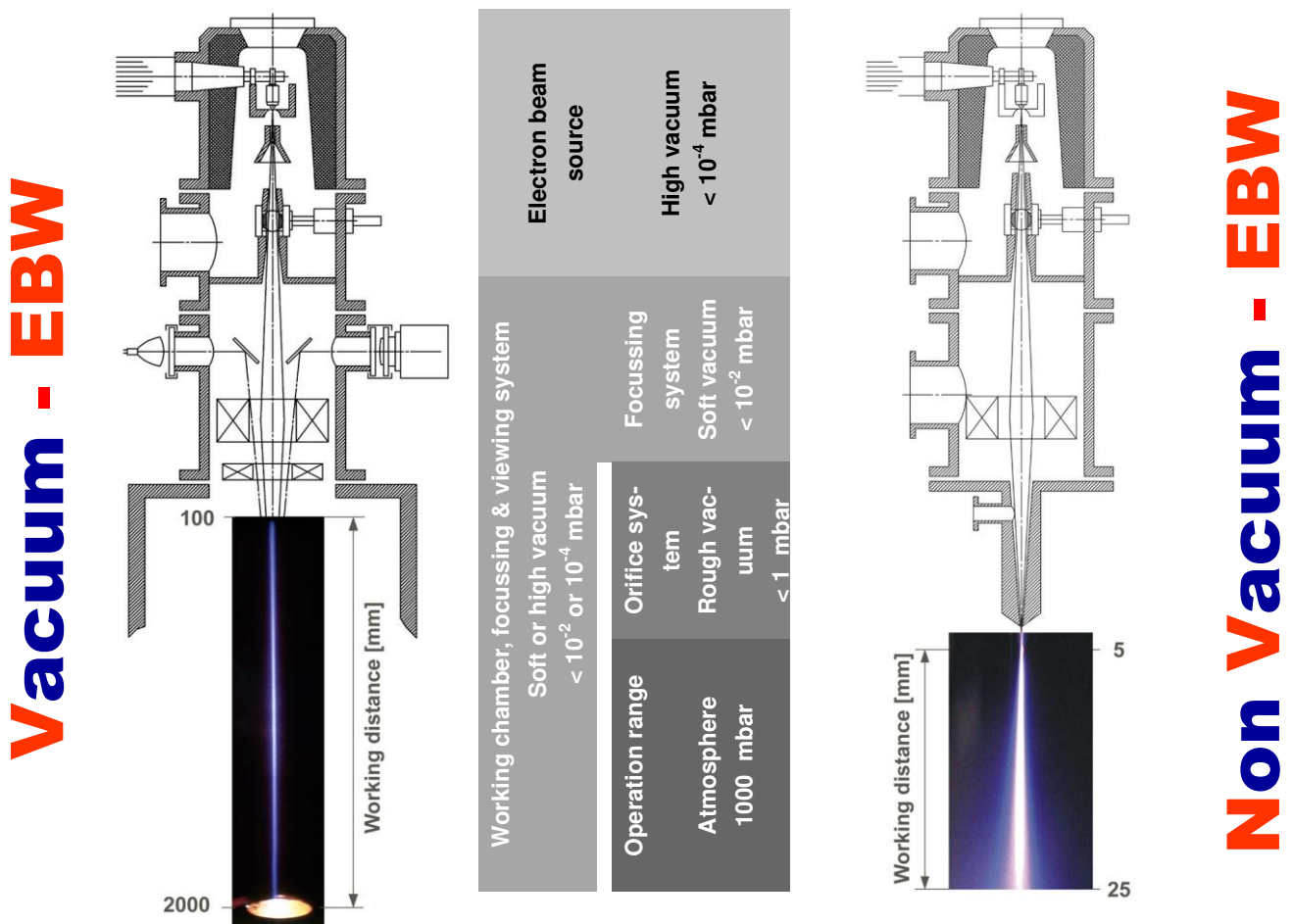

The Orifice System DSS

The compact, rotation symmetrical construction of orifice system DSS with a diameter of only 80 mm and a length of about 300 mm allows a very good accessibility even for complex components. The DSS is independent from the EB generator and can easily be changed through its bayonet fixing.

Function

By means of the DSS the electron beam is guided from the fine vacuum in the lower part of the generator column over the rough vacuum of the DSS to atmosphere (1.000 mbar).

The electron beam is focussed on the outer nozzle of the DSS. The diameter of this nozzle is between 1 mm and 2 mm.

This small nozzle makes sure that only a small amount of vaporized material can reach the rough vacuum range and the beam generator. A steady welding operation is guaranteed.

After leaving the nozzle a diffuse and diverging electron beam is formed due to the interaction of the electrons with gas molecules of the surrounding air.

The power distribution of the electron beam allows welding applications within a distance of up to 25 mm working distance.

The core diameter depends on the distance below the nozzle and is in the range between 1.5 mm and 2.5 mm for a high voltage of 150 kV.

Additionally a cross-jet of compressed air crosswise to the beam direction, seals the orifice.

The working distance must be greater than 5 mm to prevent a thermal distortion of the DSS.

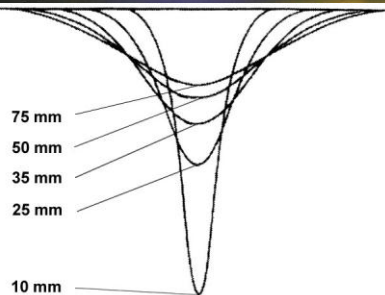

Design

In the core of the DSS the fine vacuum range of the lower part of the generator column is extended up to the inner tip of the nozzle. The shape of the inner nozzle allows a function as pressure throttle between fine and rough vacuum range.

The rough vacuum range surrounds rotation symmetrical the core and is guided to the outer outlet of the nozzle.

Compressed air, working gas and cooling water for the outlet nozzle are carried to the top of the DSS in four channels integrated in its outer casing.

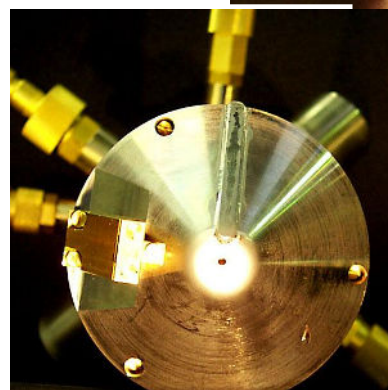
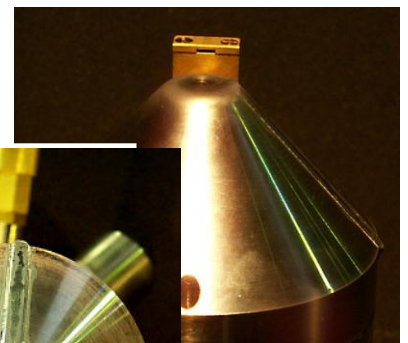
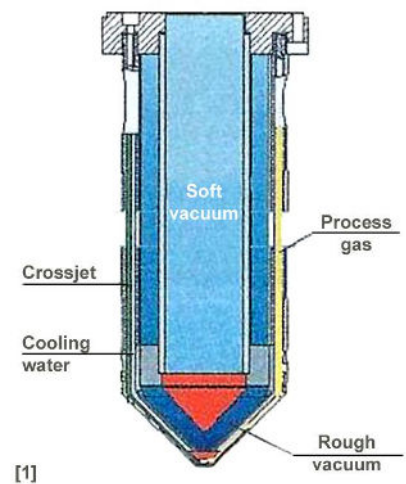

NVEBW SYSTEM

For each NVEBW system at least following components are required:

- NVEBW electron beam generator type G 300 DSS consisting of
 - electron beam generator column
 - orifice system DSS
 - high voltage power supply HVPS (30 kW beam power / 150 kV acceleration voltage)
 - vacuum systems (high, fine, rough vacuum)
- Manipulator(s) for
 - electron beam generator column
 - workpiece or clamping device
- X-ray safety protection cabin
- Control panel, PLC and CNC, electrical power supply

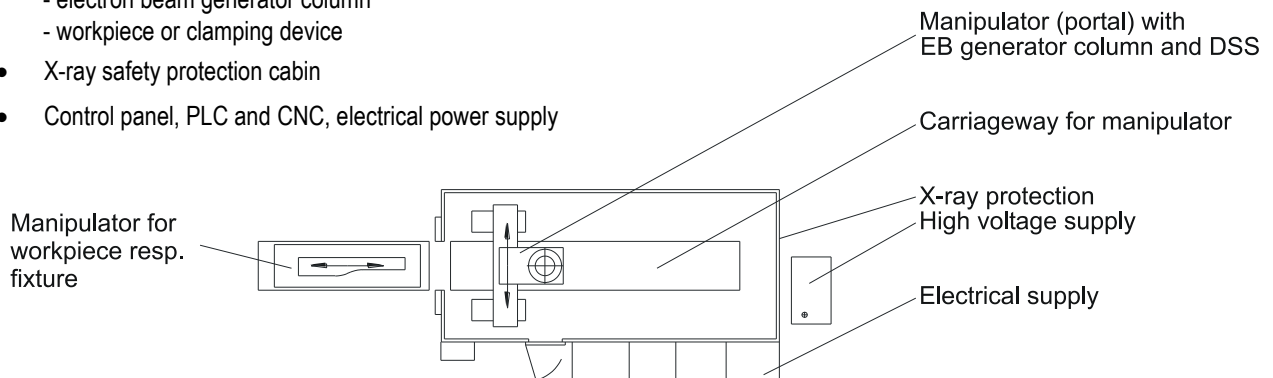

NVEB generator

The orifice system DSS is directly coupled with a bayonet fixing to the bottom side of the NVEB generator column.

Manipulation of the EB generator column

The generator column is integrated into a portal with two linear axes (Z and Y).

Two-dimensional welding already jobs can be realized with this simple and compact component.

Vacuum systems

For optimum use of the pumping capacity all the vacuum pumps for high-, fine- and rough vacuum are arranged either on the rear of the portal, or directly at the generator column.

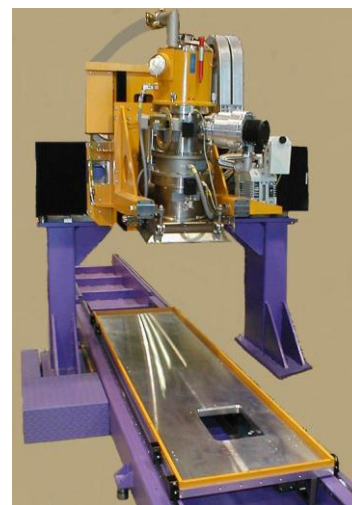
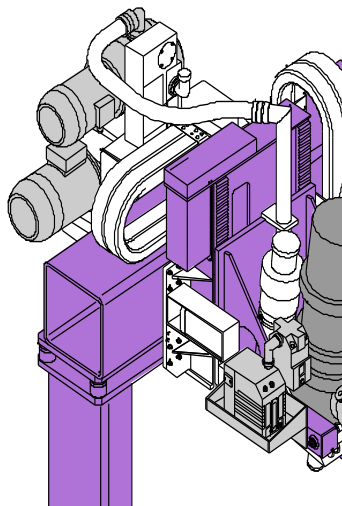

Portal with linear movement; X-table

Manipulation of work-piece and clamping device

For three dimensional processing an additional axis to the existing portal axes (Z and Y) is necessary. The workpiece respectively the clamping device has to be moved in at least one direction (X) and if required also in multi axle. Linear or rotating axes or combinations of them are conceivable.

X-ray protection

The processing area is completely covered with a cabin to protect the machine operators. The walls are sandwich panels in a combination with steel and lead.

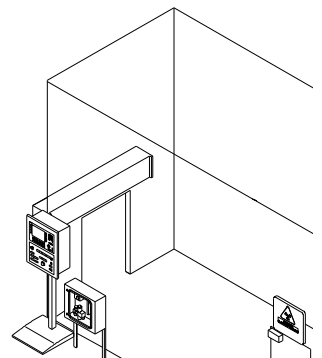

EBONOVA - the flexible NVEBW concept

NVEBW machine layouts

Depending on welding task 2D- or 3D formed parts, piece number, flexibility and available invest a lot of NVEBW machine combinations are possible. Basically it will be possible to upgrade a two axes portal (Y, Z) for manipulation of the electron beam generator column and one multi axes workpiece movement (X, A, B, ..) to an almost unrestricted 3D-working range.

Following table shows some of the possible machine combinations.

EBONOVA type:	axes	layout
2.1-G300DSS SINGLE	1 NVEBW electron beam generator 2 Linear axes for EB generator column 1 Linear or rotating axis for workpiece	G 300 DSS (Z & X) (Y oder A)
2.XL.1-G300DSS BOXER	1 NVEBW electron beam generator 2 Linear axes for EB generator column 1 Linear track extended with two tables 1 Linear or rotating axis for workpiece per table	G 300 DSS (Z & X) (Y) (Y oder A)
2.2.1- G300DSS TWIN	1 NVEBW electron beam generator 2 Linear axes for EB generator column 2 Linear axes for workpiece manipulation 1 Axis per carriageway for workpiece	Typ G 300 DSS (Z & X) (Y) (Y oder A)
2.2.x-G300DSS	1 NVEBW electron beam generator 2 Linear axes for EB generator column x Linear and/or rotating axes for example: roboter for workpiece manipulation	Typ G 300 DSS (Z & X)
2.P.x - G300DSS	1 NVEBW electron beam generator 2 Linear axes for EB generator column 1 Palett conveyor with workpiece paletts x Linear and/or rotating axes for workpiece manipulation	Typ G 300 DSS (Z & X)

In case of developing a machine concept **Steigerwald Strahltechnik** will have intensive discussions with customer, to find a optimum technical and economical solution.

EBONOVA 2.1 – G 300 DSS – TWIN Welding machine for mass production

The product: Instrument panel beam

During the 1990's a new design concept at **VW** led to changes in design of instrument panel beams; originally made of spot-welded steel the new design employed aluminium with a weight reduction of 40 %.

The new design developed by **ALCAN** is made of two AlMg3 shells with a sheet thickness of 2.5 mm and flange joint of 1,400 mm on both sides.

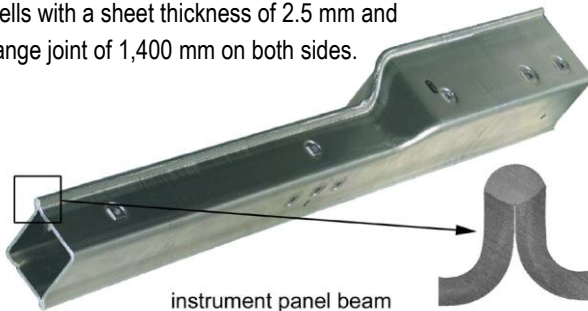

Exacting requirements such as high speed welding, rapid production rates, low energy input for minimal thermal distortion and savings in filler material have led to the introduction of non-vacuum EB; NVEBW.

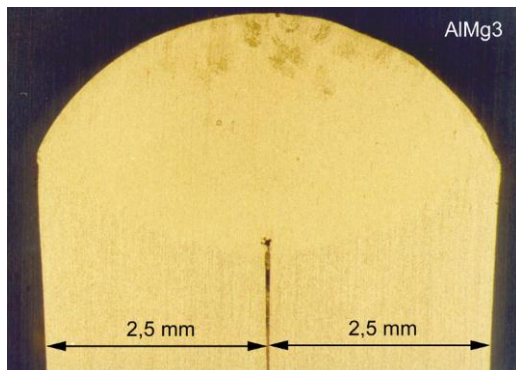

flange joint:	beam power	18 kW
	welding velocity	12 m/min

ALCAN and **Steigerwald Strahltechnik** developed the NVEB welding system in order to achieve a production rate of 500,000 instrument panels a year - two welds on each part.

A machine layout for mass production

EBONOVA 2.1 – G 300 DSS – TWIN.

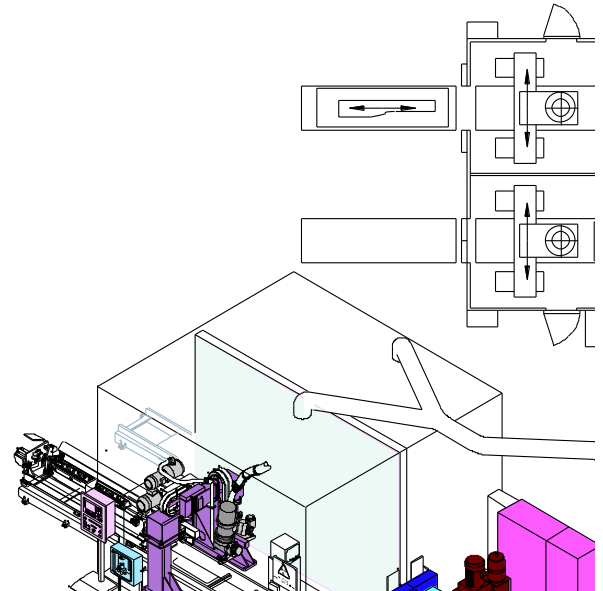

In general the machine layout consists of two separate welding cells each with one linear movement for workpiece and a manipulator for the generator column but with one high voltage supply HVPS together, control cabinet, fume extraction and other auxiliary aggregates.

The "TWIN" principle with switch able high voltage supply makes a high "beam on" time and productivity of the complete machine possible. The two separated welding cells also allow service works in one cell whereas production is running in the other.

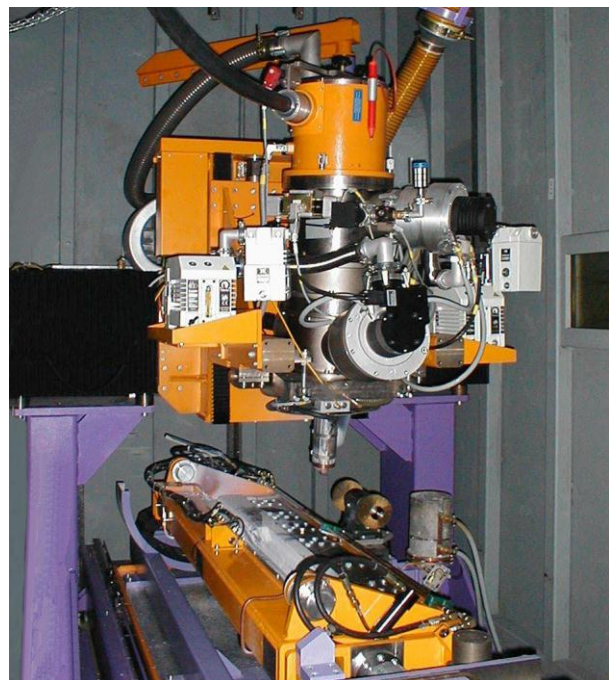

EB generator with portal and clamping device

Process technology

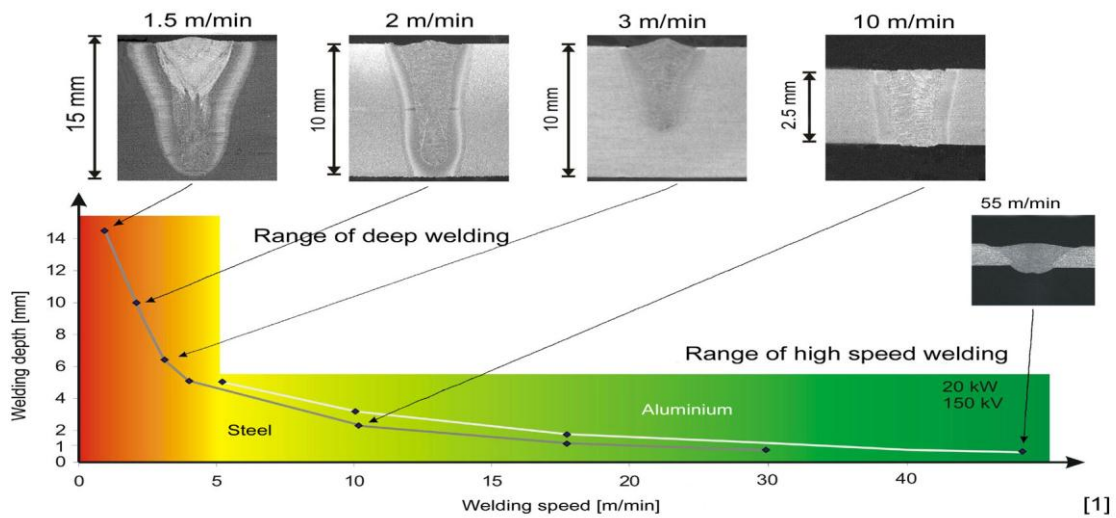

High speed welding

The classical field of application for the NVEBW is welding of thin metal sheets (< 5 mm). In this case the electron beam at atmospheric pressure with its high energy density and an output power of 30 kW can reach welding speeds of up to 20 m/min for steel and up to 50 m/min for aluminium alloys.

Deep penetration welding

Deep penetration welding is mainly characterized that welding depth is much bigger than welding width. With NVEBW depth-width-ratios of 5:1 can be reached. Deep penetration welding allows to extend the field of NVEBW applications. Up to now mainly the thin metal sheet range up to 5 mm was studied. Now more than ever welding depths with 10 mm are reached..

Gap bridging and working distance

The diverging and high-energy electron beam permits a good gap bridging without using filler material and is insensitive to working distance variations and pollution. Low heat input from the electron beam minimises thermal distortion of the workpiece.

Gaps between 1/10 up to 1 mm can be tolerated depending on the design of construction, sheet thickness and welding velocity. To avoid a weld sink in case of big gaps, the joining design must ensure that enough material is available.

Joining design

Flange joint and overlap joint are ideal joints for NVEBW. Due to the big material quantity a coarse joint preparation and relative big gaps are possible. Gas-proof and water-proof joints can also be achieved.

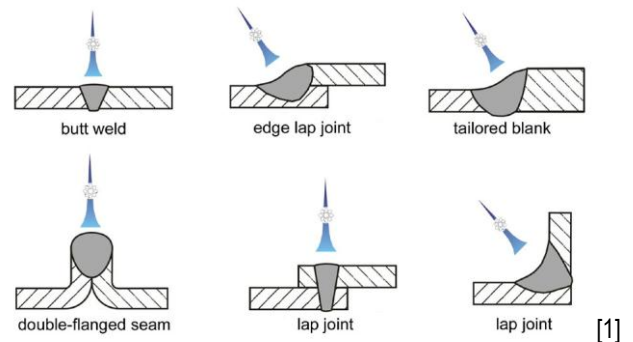

The „Tailored Blank“ joint allows gaps of a few 1/10 mm. In case of a butt weld gaps with $< 1/10$ mm are tolerated only.

Filler material

Filler material can be used if the joint design do not allow to avoid weld sink. In this case the welding velocity is reduced.

Processing gas

Helium is used as working gas/protecting gas. The working gas protects mainly nozzle and beam generator against pollution but not the workpiece. Furthermore, He with its small atomic diameter which flows inside and outside of the nozzle, minimizes the expansion of the electron beam.

Parameters

The gas quantity and the working distance are important parameters beside the beam parameters as beam current and acceleration voltage. They all influence welding velocity, welding depth and joint quality.

Welding results

During the development of the DSS **isf** - Institute in Aachen – carried out a number of NVEBW welding experiments with different materials to evaluate the process and to identify potential application opportunities.

Up to now material investigations were made with steels and galvanised steels, non-ferrous metals such as copper, brass, aluminium and magnesium alloys. Mixed materials combinations such as steel and copper are also possible to weld with comparable results to the VEBW.

Steels [1]

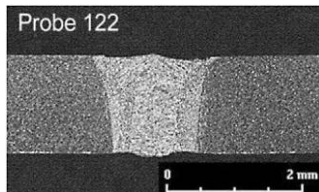

Butt weld
 Thickness: 1.5 mm
 Material: ZStE 420
 Beam power: 15 kW
 Welding velocity: 10.5 m/min

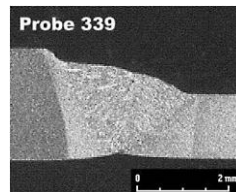

Tailored-blanks
 Thickness: 1.5 mm / 2.5 mm
 Material: St 1405 / ZStE 420
 Beam power: 15 kW
 Welding velocity: 8 m/min

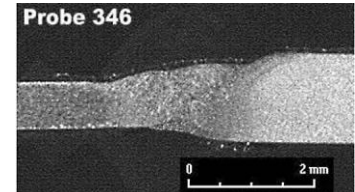

Tailored-blanks
 Thickness: 0.7 / 1.5 mm
 Material: St 1405 / ZStE
 Beam power: 15 kW
 Welding velocity: 21,6 m/min

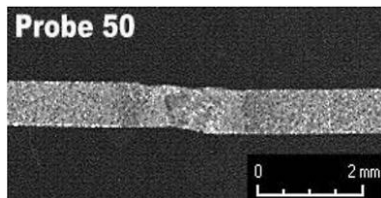

Butt weld
 Thickness: 0.7 mm
 Material: St 1405 FZ
 Beam power: 9 kW
 Welding velocity: 15.3 m/min

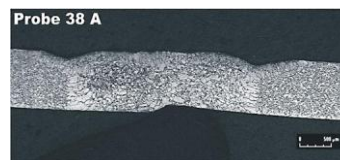

Butt weld
 Thickness: 0.7 mm
 Material: St 1405 FZ
 Beam power: 18 kW
 Welding velocity: 25 m/min

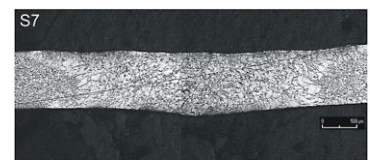

Butt weld
 Thickness: 0.7 mm
 Material: St 1405 FZ
 Beam power: 13 kW
 Welding velocity: 20 m/min

Non-ferrous metals [1]

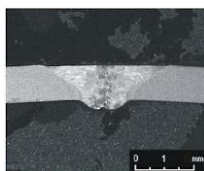

Butt weld
 Thickness: 1.25 mm
 Material: AlMg 5
 Beam power: 18 kW
 Welding velocity: 40 m/min

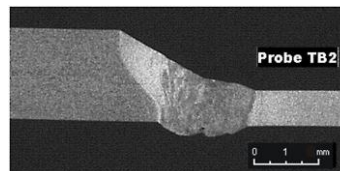

Tailored-blanks
 Thickness: 1.25 / 3 mm
 Material: AlSi / AlMg 5
 Beam power: 9 kW
 Welding velocity: 10 m/min

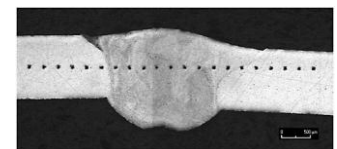

Butt weld
 Thickness: 1.1 mm
 Material: AlMgSi 0.8 + ZWS
 Beam power: 18 kW
 Welding velocity: 55 m/min

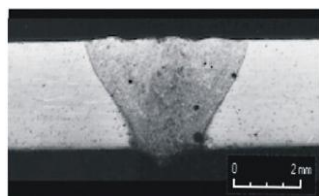

Butt weld
 Thickness: 3 mm
 Material: AZ 31
 Beam power: 6.3 kW
 Welding velocity: 15 m/min

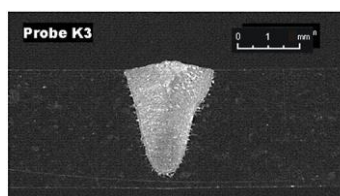

Penetration weld
 Thickness: 4 mm
 Material: Copper
 Beam power: 6.3 kW
 Welding velocity: 5 m/min

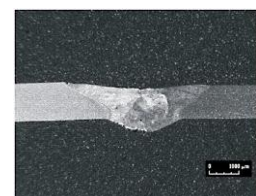

Butt weld, material combination
 Thickness: 1.25 / 1.1 mm
 Material: AlMg 5 / AlMgSi 0,8
 Beam power: 18 kW
 Welding velocity: 40 m/min

Efficiency

As high energy beam processing the electron beam welding at atmospheric pressure is in direct competition with the LASER beam welding. Therefore a comparison of both technologies in respect of economical aspects is of high importance.

NVEBW

In the NVEBW process the kinetic energy of the electrons initiate the melting of material and continue the process. The electrons induce deep welding process with high efficiency independent of material, angle of incidence and surface quality. In general additional protecting gases are not required.

LASER

The LASER as monochromatic and coherent light wave reaches similar energy densities as the electron beam. However the absorption of metals restrict the field of application for laser welding. Depending on wave length (Nd:YAG or CO₂) and metal the absorption is only in a range between 1 % and 10 % against 90 % for NVEBW.

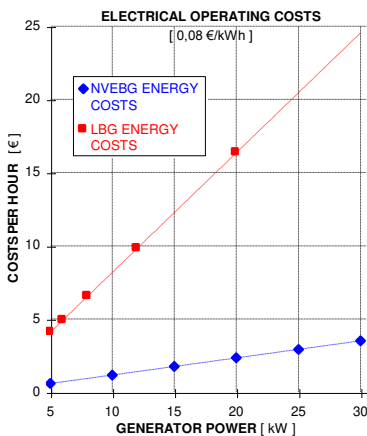
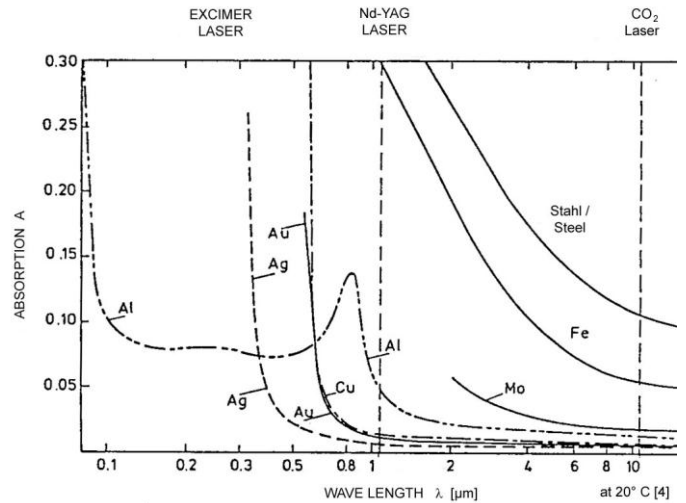

Comparison

When we compare invest, operating costs, beam and machine efficiency of NVEBW with the LASER it is turned out that with the NVEBW a very high amount of energy can be saved.

The total efficiency of a LASER welding machine is in a range between 5 % to 15 % but the NVEBW exceeds 60 %.

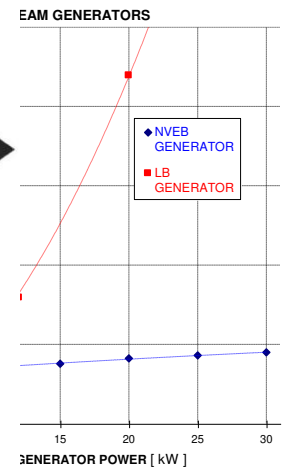
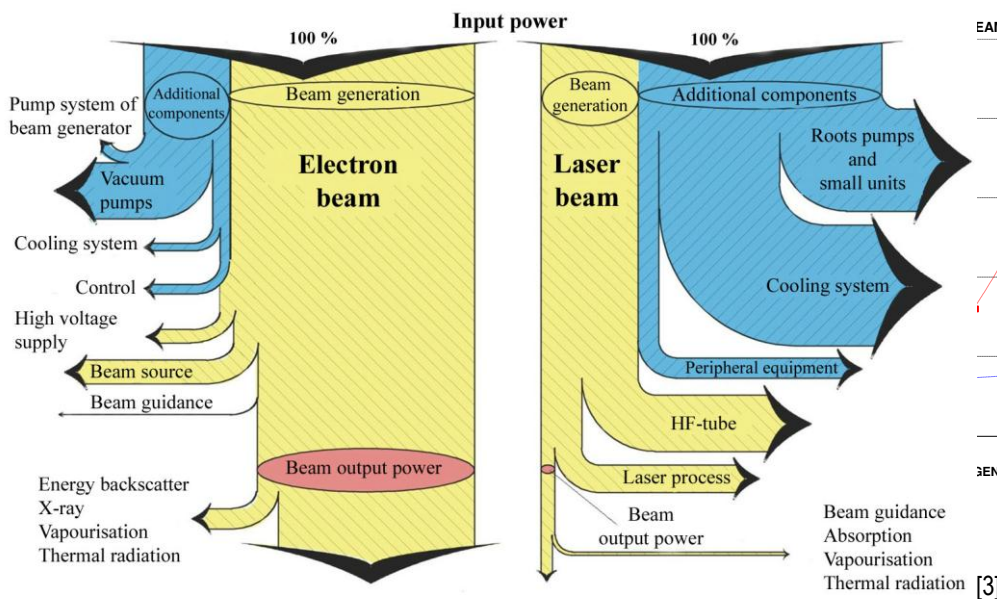
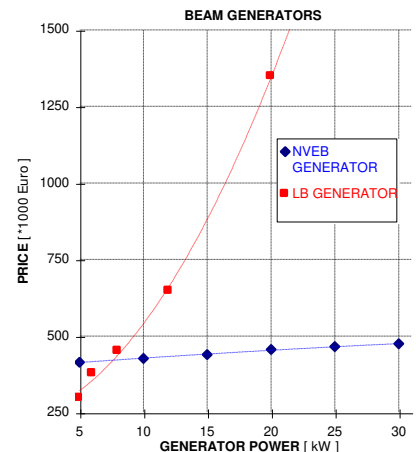

Know-how and after-sales support - committed to the customer on an international level

Investments in industrial machinery are the results of carefully considered decisions. That's why our comprehensive customer support is available to you right from the start to help you make the right decision. And you can depend on us for optimum system solutions based on up-to-date, efficient technology designed to meet your specific, individual requirements. Above all, customer support remains our top priority for the full service life of your system.

Steigerwald Strahltechnik does not only supply EB installations but also engages in studies concerning specifically defined user applications. We also make the know-how of our decades of experience in the field of EB technology available to our customers.

Extensive training of customers' personnel is just as well part of our services as the world-wide supply with spare parts and qualified after-sales support.

Reference

[1] **Steigerwald Strahltechnik**

expresses its thanks to Prof. Dr.-Ing. U. Dilthey and Dr.-Ing. W. Behr of "Institut für Schweißtechnische Fertigungsverfahren der Rheinisch-Westfälischen Technischen Hochschule (RWTH) Aachen" for their technical support and putting numerous photos at our disposal.



[2] Volkswagen AG, Wolfsburg

[3] DVS Merkblatt 3209

[4] U. Bethke, D. Pätke, P. Zopf, Aluminiumschweißen mit Festkörperlaser, Vorstudie INPRO, S.12, 1993

EBONOVA-E

The descriptions, technical data, and illustrations contained in this document are provided for guidance purposes only and are non-binding. The manufacturer reserves the right to make alterations to products without notice.

© Steigerwald Strahltechnik GmbH 06/2010